

Thermo-Form Corner Set Dimensions

Nominal System Width	Length of Outside Leg (A)
4"	4 5/16"
6"	6 5/16"
8"	8 5/16"
10"	10 5/16"

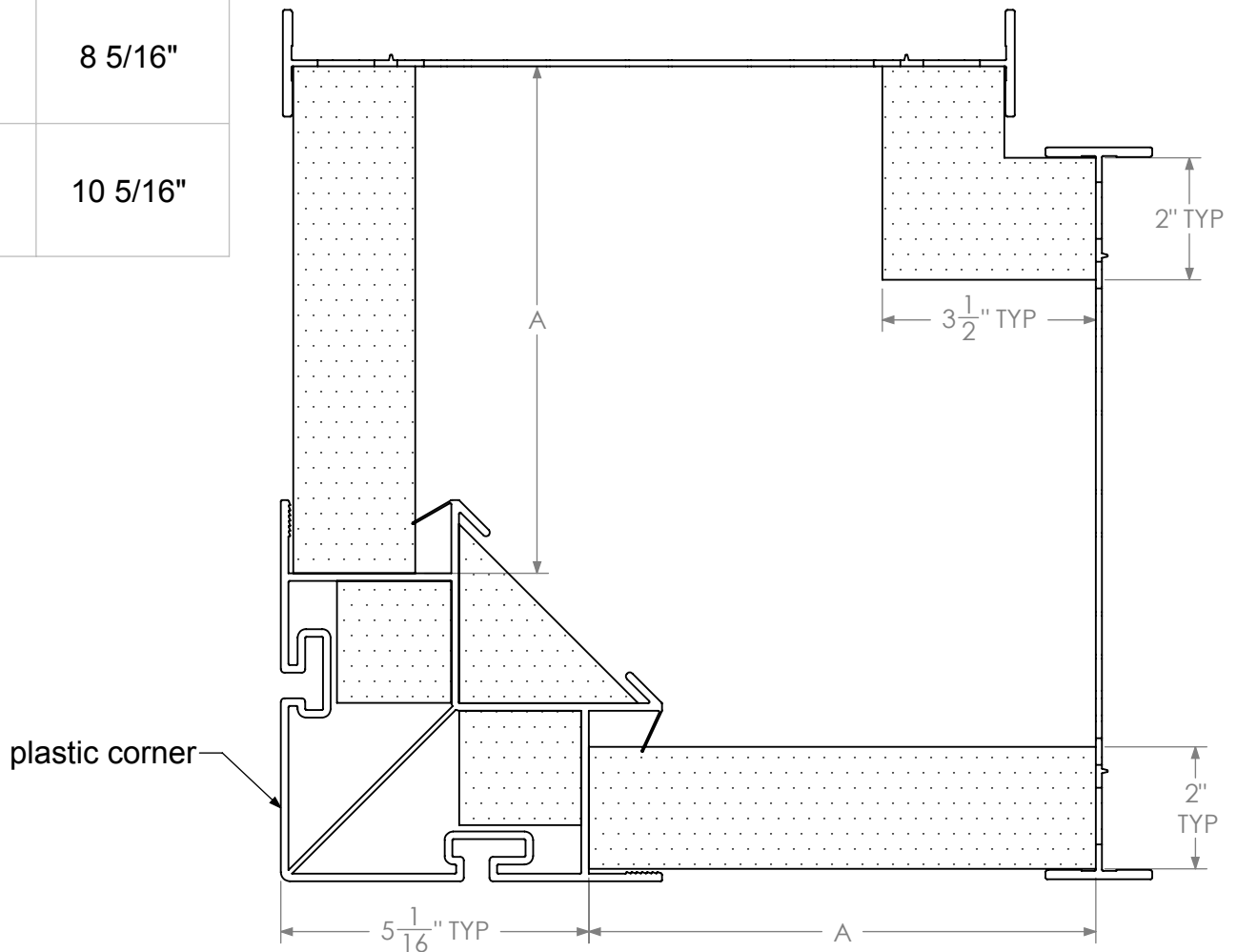

Plastic 90° Corner Sets

TF Forming Systems, Inc.
800-360-4634
www.TFSystem.com

Date: 9/24/2010

rip 4' x 8' DOW boards into 6 equal panels
(approximately 7 7/8" wide x 8' long)

table saws work best for cutting panels

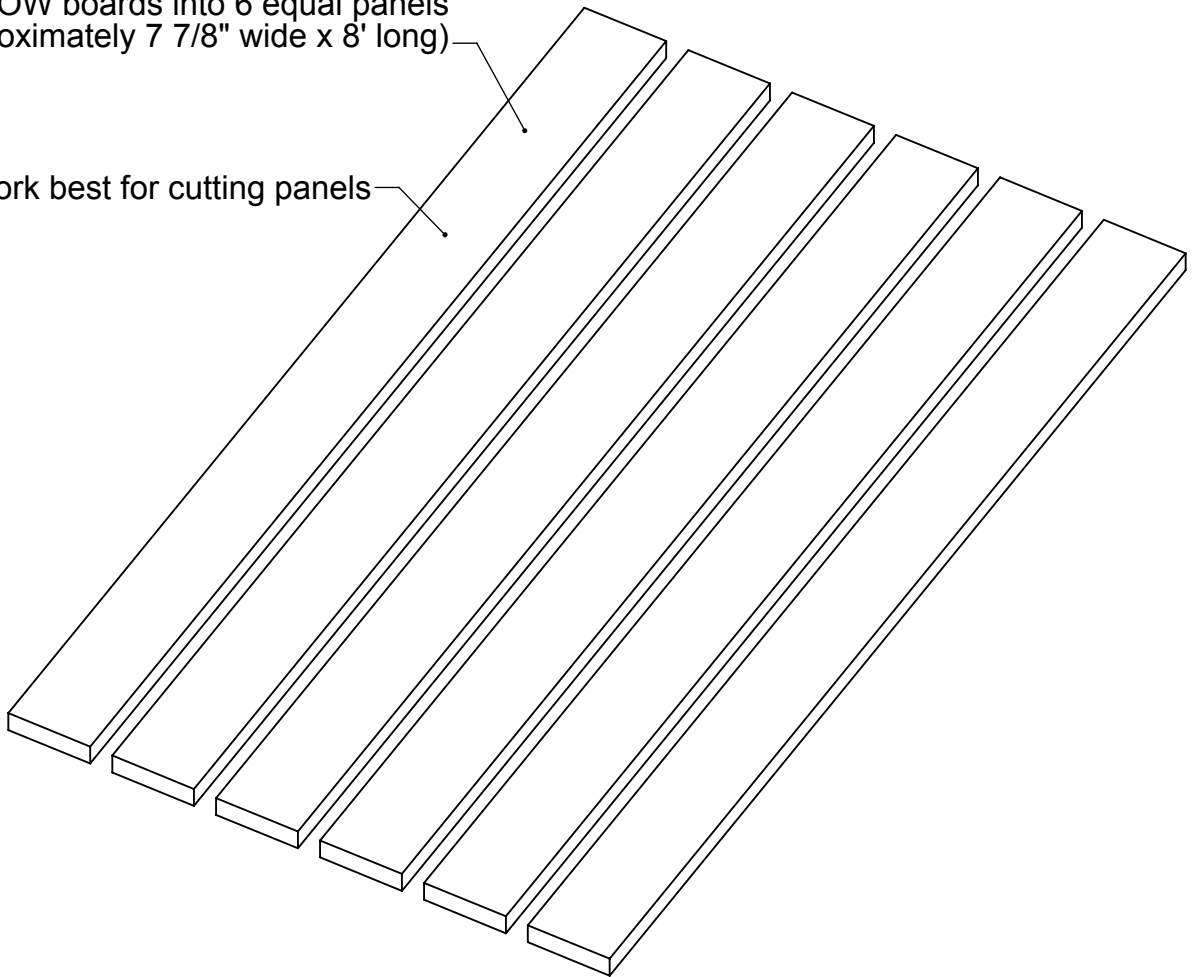

use 2" thick non-scored 250 PSF DOW™ board
donated from the Dow Chemical Company

2" poly panels are ungrooved; lateral ties are required to hold them in place

lateral ties slide between tabs on stud rails and poly panels

lateral ties hold stud rails together & secure poly panels

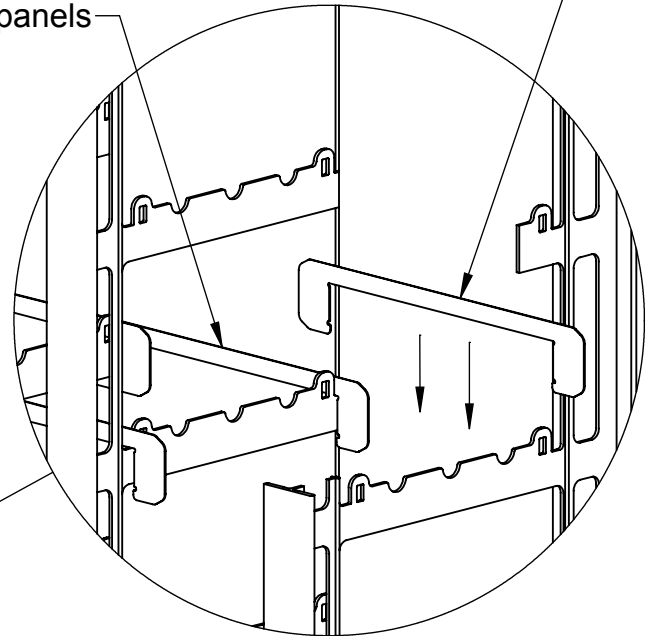
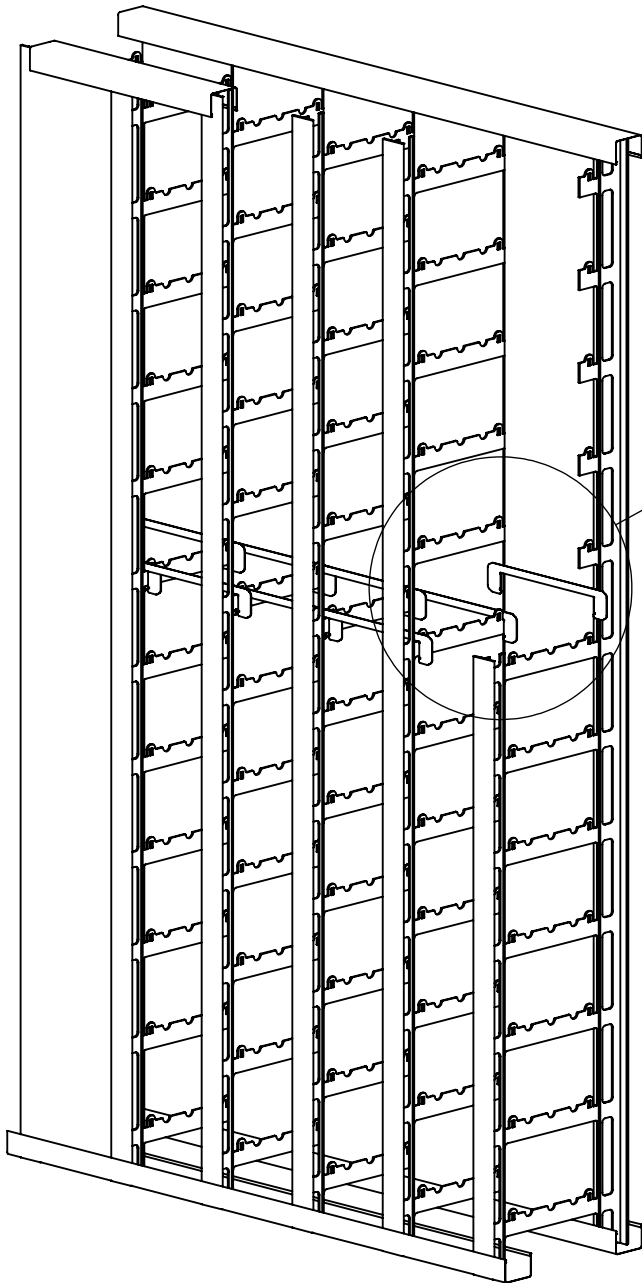

One pair of lateral ties is needed for each 8" section of wall; lateral ties are installed approximately halfway up the wall.

Lateral Ties

TF Forming Systems, Inc.
800-360-4634
www.TFSystem.com

Date: 9/13/2010