

## Concrete

- Always follow project specific engineering and applicable codes when determining the concrete mix design.
- A standard 3/4" aggregate wall mix is suitable in most cases.
- TF Forming Systems, Inc. recommends a 5" slump and professional consolidation.

### Methods of placing concrete

- Front discharge concrete truck (recommended)
- Concrete pump truck (recommended)

\*Use a 5" to 3" reducing flexible hose

or

\*Reduce to a 3" hose with a double 90° bend on the end and shut off if available.

- Rear discharge concrete truck
- Trailer or "pony" pump
- Conveyor Truck
- Crane and bucket

### Pouring tips

- Pour in approximately 4' lifts.
- Break the fall of the concrete by forcing the concrete to fall over the cross ties of the stud rails, rebar intersection, or a square shovel.
- Consolidate each lift separately without over consolidating the previous lift.
- Use personnel who have experience pouring concrete walls.

### Post Pour

- Smooth the top of the wall.
- Be sure to install all anchor bolts or rebar for the next level.
- Clean the c-channel after the pour. (A small piece of polystyrene works well.)



Concrete Placement

TF Forming Systems, Inc.  
800-360-4634  
[www.TFSystem.com](http://www.TFSystem.com)

Date: 2/1/2010

## **Consolidation**

### **Mechanical vibration**

Use a 1" maximum diameter concrete vibrator to internally consolidate the concrete. Contact a TF Forming Systems, Inc. technical representative before using a vibrator larger than 1".

Concrete should be a 5" slump.

Stay at least six feet behind where the forms are being filled.

On the first lift, run the vibrator down to the footing and pull it back up once in every cell between the I-beams. You should see some water trickle out the bottom of the forms between the footing and the C-channel. If no water trickles out, your concrete slump needs to be checked; the concrete may not be flowing freely enough. For the second and succeeding lifts, drop the vibrator head one foot into the preceding lift to help knit the lifts together.

### **Vibrating Walls: Do's and Don'ts**

**Do** understand that any form system can be blown out by over vibrating. Common sense is a must!

**Do** vibrate concrete walls whenever possible. A stiffer mixed concrete that is vibrated has much less head pressure than a wetter mixed concrete that is not vibrated.

**Don't** allow vibrator to sit in one spot. Always keep it moving.

**Don't** try to move or flow the concrete in the wall forms with a vibrator.

**Don't** pour a stiff mix in any wall that will not be vibrated. The chances of getting a void or honeycomb in the wall are significantly increased.

### **External Consolidation**

If you do not have access to a mechanical vibrator, use a hammer and piece of wood to tap the exterior of the wall.

Concrete should be at a 6" slump when externally consolidating.

Stay at least 6 feet behind the filling position.

Place the board horizontally across two I-beams and tap with a hammer twice at several levels of each poly panel. Use medium velocity taps.

**Common sense must be used. Vibrating walls takes skill and knowledge. You can blow out any form system if consolidation is done incorrectly.**

## **Repairing a blowout**

Occasionally a poly plank will fail, or "blowout" as it is commonly referred to, and concrete will escape from the form. This can be the result of improper bracing, lack of bracing in the necessary locations, incorrect pouring techniques, or a plank that was damaged in transport or installation.

### **Rule No. 1 - Don't Panic!**

Blowouts happen with any type of concrete form including steel, plywood, and aluminum. One advantage of the Thermo-Form system is that a blowout will only affect one plank; thus you will lose only a small amount of concrete, and if repaired correctly the resulting wall will be dimensionally correct and nobody will ever know the difference.

### **Rule No. 2 - Don't Rush it!**

Let the concrete set up slightly so it doesn't continue to run out of the form as you start to repair it. Use this time to organize the tools you will need to complete the repair. You will likely need a shovel and wheel barrow, drywall saw, handsaw, screw gun and screws, and plywood or lumber to cover the replacement plank.

### **Rule No. 3 - Don't Hold up the Pour!**

Have the rest of your crew continue to pour in another area while you repair the form. A blowout is no reason to risk the wrath of the concrete company by keeping their trucks on the job site too long.

**Step No. 1 - Remove the concrete** that has spilled from the form. It can be put back into the wall if possible or spread out in a thin layer to keep from interfering with pouring the concrete floor (if this is a basement pour).

**Step No. 2 - Remove the damaged plank**, or as much of the damaged plank as is required to complete the repair. If a portion of the plank is intact it may still be used in the form.

**Step No. 3 - Replace the damaged plank** or the portion of the plank that is damaged with a replacement plank that has been trimmed to 6 ¼" wide allowing it to be simply pushed in place from ground level. (See the diagram on the facing page.)

**Step No. 4 - Hold the replacement plank in place** with plywood or lumber bracing. Remember, the replacement plank will not stay in place by itself!

**Step No. 5 - Carefully place concrete in repaired area** in a few lifts so as not to put undue strain on the repaired area.

If these directions are followed carefully a blowout is quickly and easily repaired and does not affect the pour or the resulting wall in any way. The replacement poly plank will adhere to the concrete behind it and will stay in place after the temporary bracing is removed.

1. Remove spilled concrete.
2. Cut out damaged area with a drywall saw.
3. Replace with new panel that has been trimmed to 6 1/4" wide.
4. Screw plywood or 2x4's into stud rail to hold patch panel in place.

**Replacement panel will not stay in place without bracing.**

5. Carefully place concrete in repaired area in a few lifts.

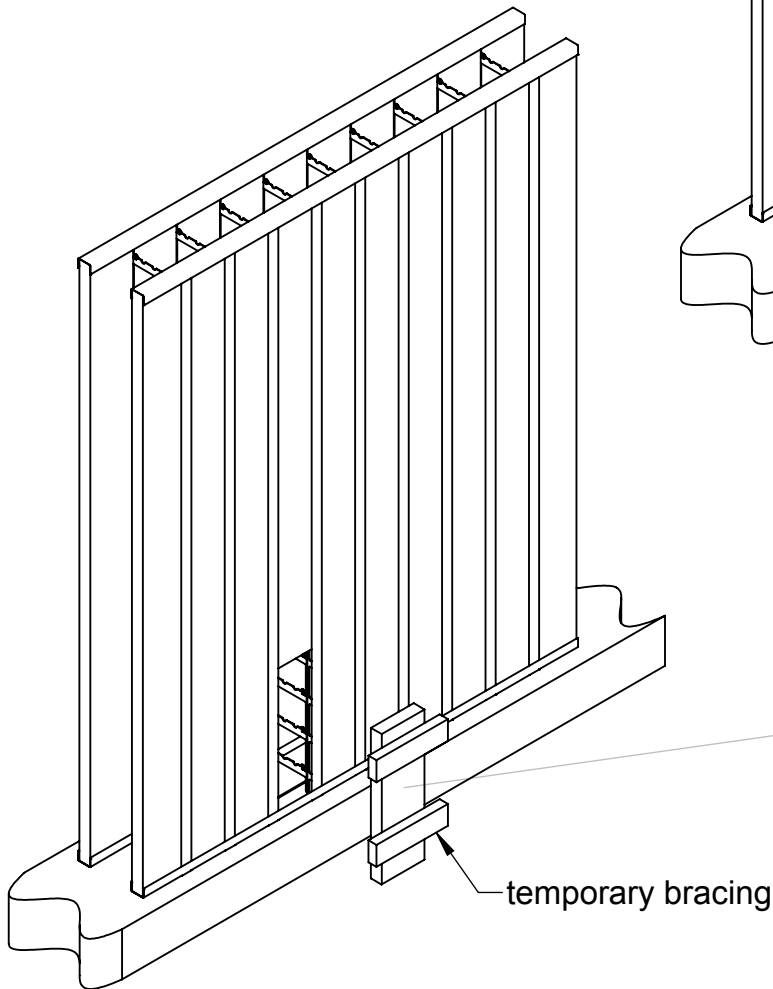
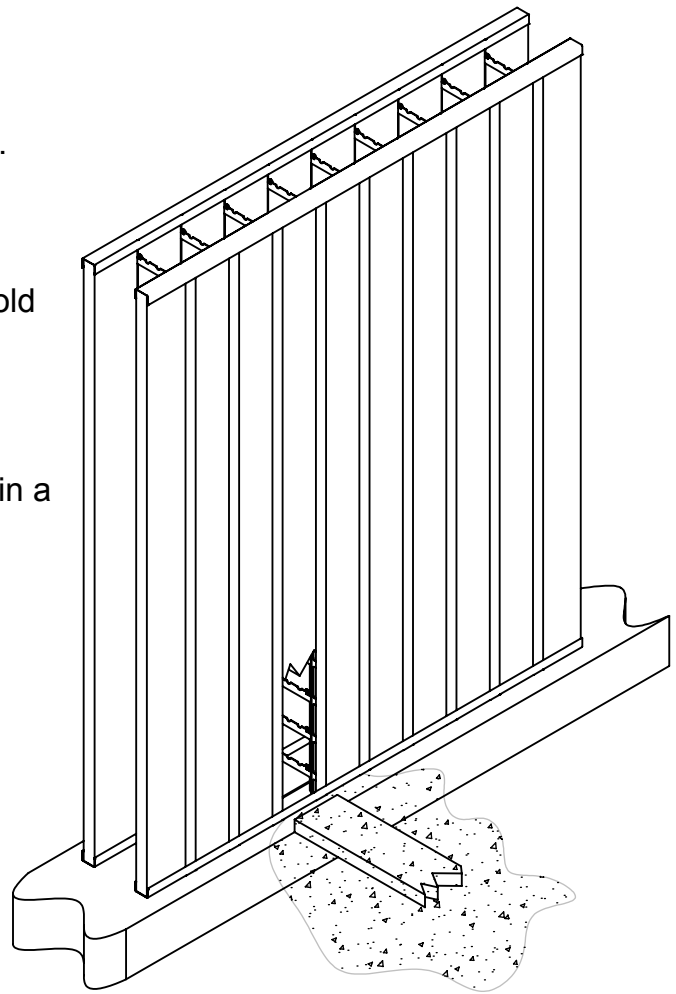

trim extra from standard poly panel

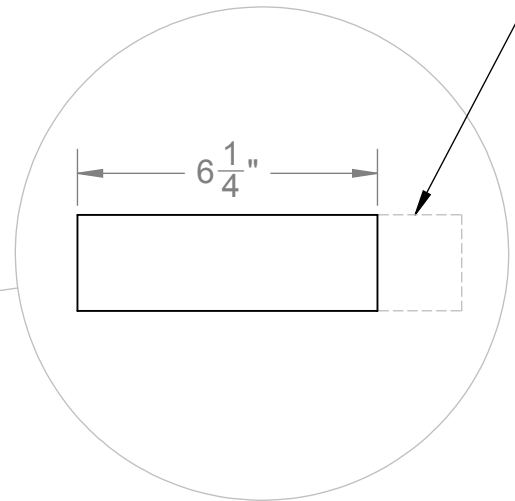

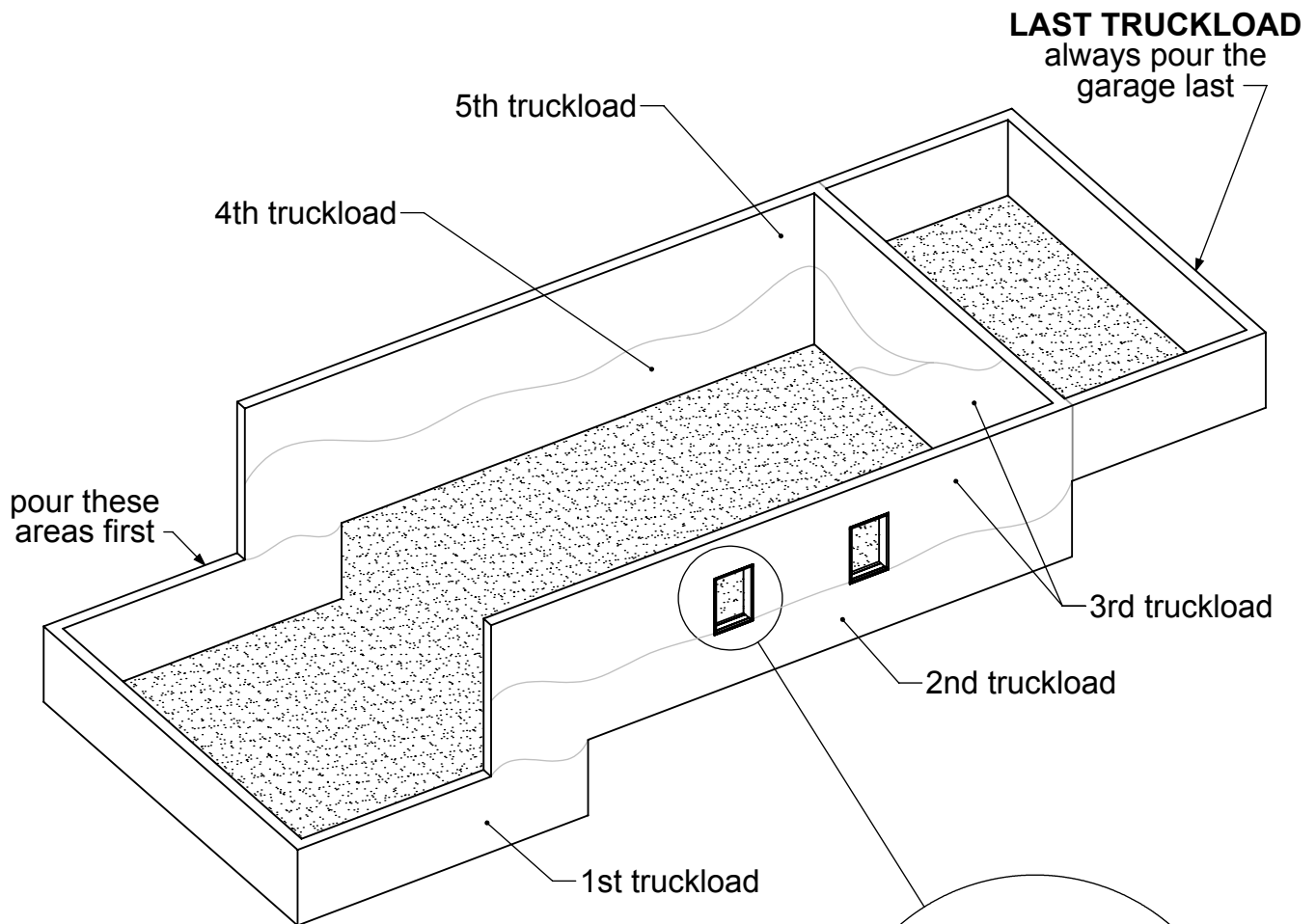

-Pour in approximately 4 foot lifts.

-Let the first lift set for approximately 15-20 minutes before starting the second lift.

-Consolidate each lift after it is placed. Use a 1" maximum diameter vibrator. Do not over consolidate.

-Pour frost walls first. Allow time for the concrete at the step transition to take the initial set.

-Pour garage frost walls last. If the volume of concrete is short, this section of wall is less critical and can usually be reached with a chute, which will reduce the amount of time a pump truck is needed on site.

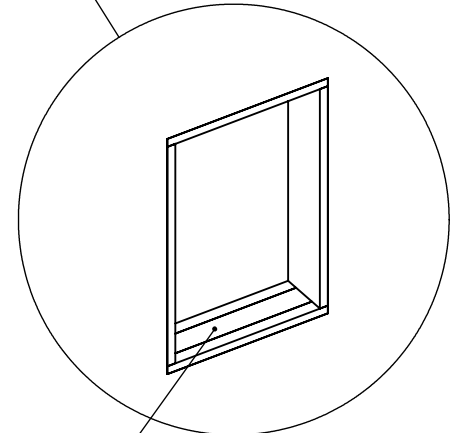

make sure that concrete has filled the cavity underneath the windows in the first lift

## Pouring Example

TF Forming Systems, Inc.  
800-360-4634  
www.TFSystem.com

Date: 1/13/2010